

PART NUMBER	BELT WIDTH	DIMENSION "A" BLADE COVERAGE	DIMENSION "B" FRAME LENGTH
36898-54XX48XX	54.00 [1400-1600]	48.00 [1219]	86.00 [2184]
36898-54XX52XX	54.00 [1400-1600]	52.00 [1321]	86.00 [2184]
36898-60XX54XX	60.00 [1600-1800]	54.00 [1372]	98.00 [2489]
36898-60XX58XX	60.00 [1600-1800]	58.00 [1473]	98.00 [2489]
36898-66XX60XX	66.00 [1600-1800]	60.00 [1524]	104.00 [2642]
36898-66XX64XX	66.00 [1600-1800]	64.00 [1626]	104.00 [2642]
36898-72XX66XX	72.00 [1800-2000]	66.00 [1676]	110.00 [2794]
36898-72XX70XX	72.00 [1800-2000]	70.00 [1778]	110.00 [2794]
36898-78XX72XX	78.00 [1800-2000]	72.00 [1829]	117.00 [2972]
36898-78XX76XX	78.00 [1800-2000]	76.00 [1930]	117.00 [2972]
36898-84XX78XX	84.00 [2000-2200]	78.00 [1981]	123.00 [3124]
36898-84XX82XX	84.00 [2000-2200]	82.00 [2083]	123.00 [3124]
36898-96XX90XX	96.00 [2200-2400]	90.00 [2286]	135.00 [3429]
36898-96XX94XX	96.00 [2200-2400]	94.00 [2388]	135.00 [3429]

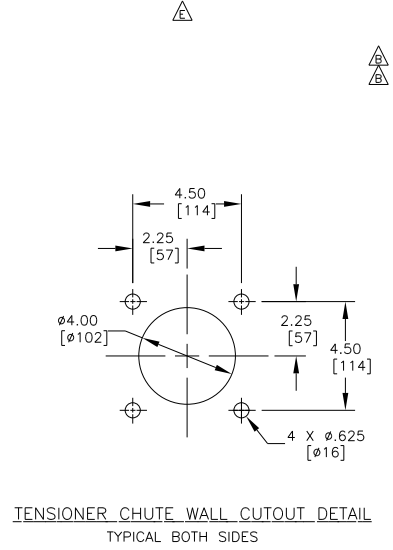

- NOTES:
- 1) ALL DIMENSIONS ARE GIVEN IN INCHES (MM) AND ARE FOR REFERENCE ONLY.
 - 2) FRAME IS ADJUSTABLE TO DESIRED LENGTH.
 - 3) FIRST XX INDICATES BELT WIDTH. THIRD X INDICATES BLADE WITHOUT SLITS. FOURTH X INDICATES BLADE WITHOUT SEGMENTS. THE NEXT TWO XX'S INDICATE BLADE WIDTH. THE REMAINING X'S INDICATE BLADE COLOR.
EX: 36898-540048 = 54" BELT WITH 48" ORANGE BLADE WITH SLITS AND SEGMENTS.
36898-541052GR = 54" BELT WITH 52" GREEN BLADE W/O SLITS WITH SEGMENTS.
36898-540148BR = 54" BELT WITH 48" BROWN BLADE WITH SLITS W/O SEGMENTS.
36898-541152 = 54" BELT WITH 52" ORANGE BLADE W/O SLITS OR SEGMENTS.
 - 4) FOR BELT WIDTHS 48.00 (1219) AND UNDER, MARTIN® ENGINEERING RECOMMENDS USING A TWIST TENSIONER ASSEMBLY (P/N 31443). SEE S37250-S.
 - 5) WHERE EXTREME OR UNUSUAL CONDITIONS EXIST, OR SPECIAL MAINFRAME LENGTHS ARE REQUIRED, CONSULT MARTIN ENGINEERING FOR ASSISTANCE.
 - 6) TWIST TENSIONER ASSEMBLY MAY BE BOLTED OR WELDED IN PLACE. MARTIN® ENGINEERING RECOMMENDS BOLTING WHEN APPLICABLE FOR EASIER MAINTENANCE AND ACCESSIBILITY.
 - 7) REFER TO OPERATOR'S MANUALS (M3296 AND M3618) FOR INSTALLATION INSTRUCTIONS.
 - 8) MARTIN® ENGINEERING RECOMMENDS THE CLEANER BE LOCATED SO THAT THE BLADE TIP IS AT OR SLIGHTLY BELOW HORIZONTAL CENTERLINE OF HEAD PULLEY. CLEANER IS SHOWN BELOW IN RECOMMENDED WORKING POSITION.
 - 9) FOR SEVERE APPLICATIONS WELD MAINFRAME ADAPTER DIRECTLY TO MAINFRAME.
 - 10) THE QC™#1 HD PRE-CLEANER BLADE IS DESIGNED TO REMOVE INITIAL CARRYBACK ONLY. DO NOT OVER TENSION!
 - 11) THE QC™#1 HD PRE-CLEANER BLADE IS DESIGNED FOR HEAD PULLEYS WITH A MINIMUM EFFECTIVE DIAMETER OF 12.00 (305).

ITEM	QTY.	DESCRIPTION	PART NUMBER
1	1	MARTIN®QC™#1 HD BLADE MNFRM ASM	36898-XXXXX
2	1	MARTIN®TWIST™DUAL TENSIONER ASM	31443-2R
3	1	MARTIN®LOW PROFILE STL DOOR 9X12	CYA-0912

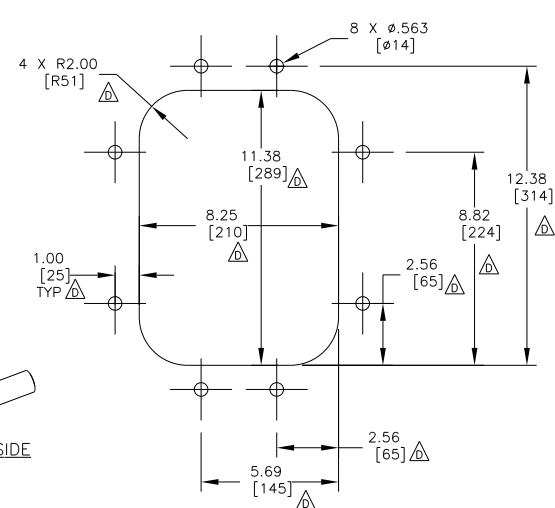
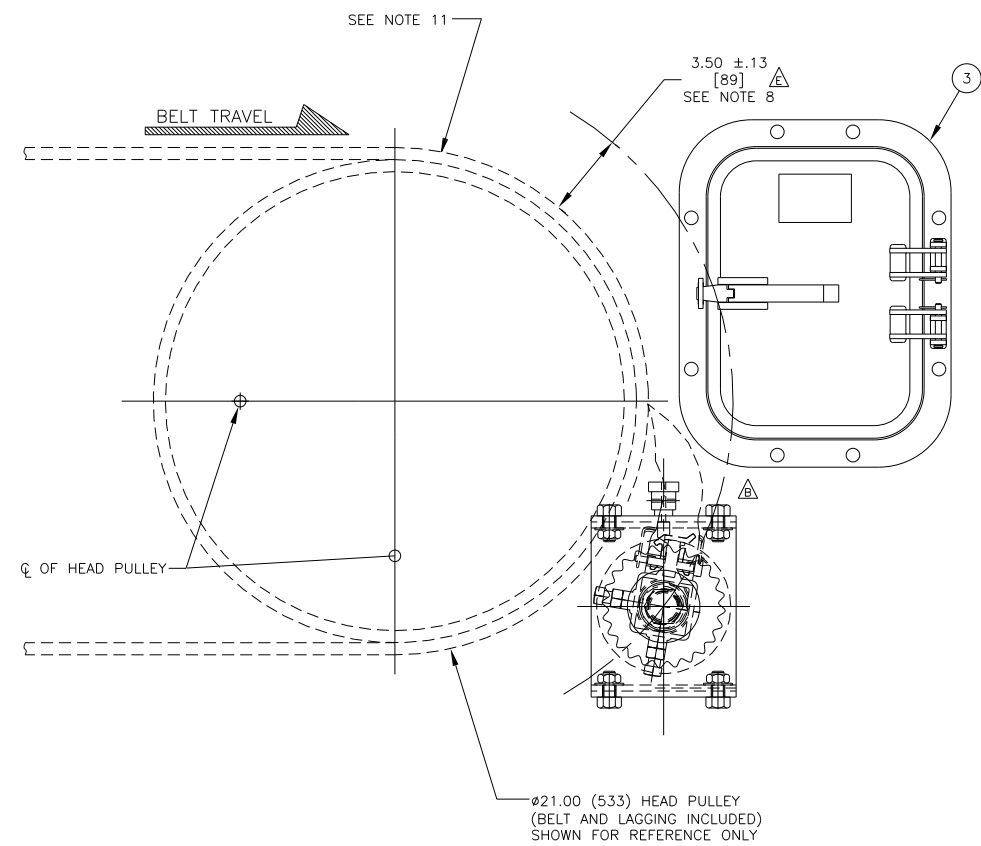
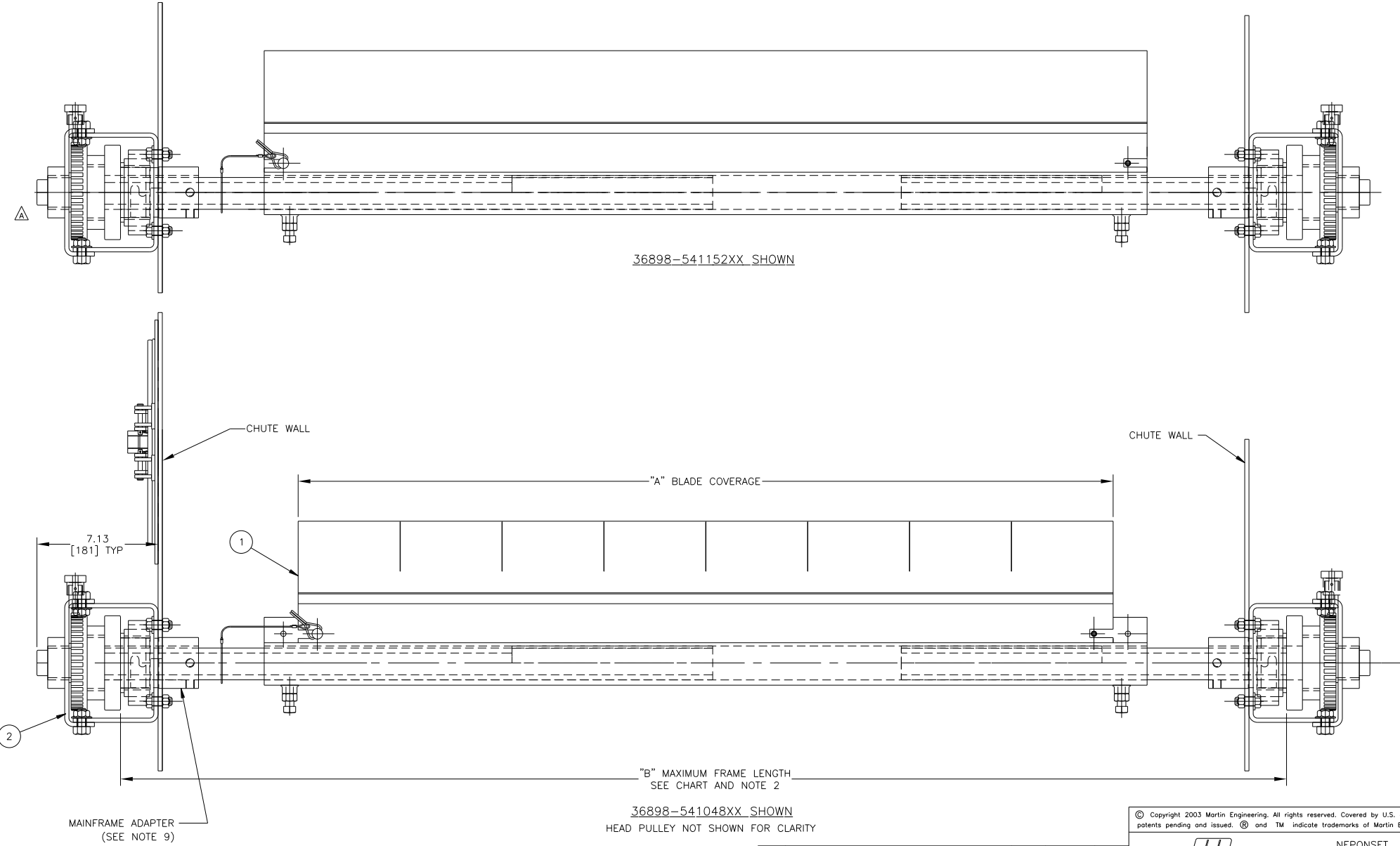
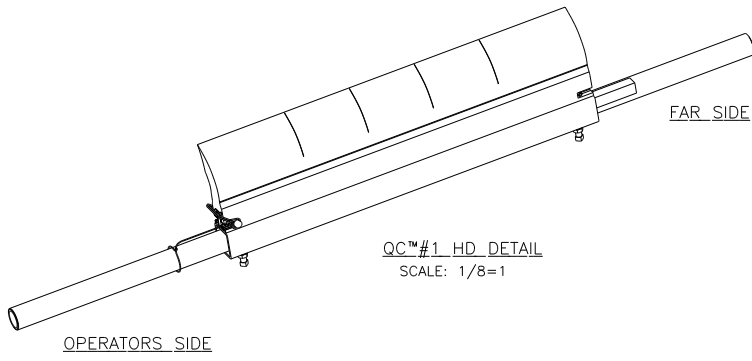

NO.	DESCRIPTION	ECN	DATE	BY
E	REV MOUNTING LOCATION CHART/CHG DIM FROM 4.00 TO 3.50 (12 THRU 15)	12821	03/18/10	MJB
D	CHG P/N FROM 34955-0912 TO CYA-0912/CHG DIM FROM 7.00 TO 7.50, 4 X R1.81 TO 4 X R2.00, .75 TO 1.00, 2.81 TO 2.56, 5.94 TO 5.69, 8.75 TO 9.25, 11.98 TO 11.38, 2.82 TO 2.56, 9.07 TO 8.82 & 12.63 TO 12.38	12561	03/24/09	MJB
C	ADDED 78 BELT WIDTH INFORMATION TO CHART (MD0704)	-----	03/15/07	RND
B	CHGD TO NEW BLADE PROFILE / CHGD DIM "D" FROM 4.50 TO 4.00 & FROM 4.00 TO 3.50	11709	07/28/06	RND
A	ADDED 2.00 LESS BELT WIDTH INFO	-----	12/16/03	JAP
NO.	DESCRIPTION	ECN	DATE	BY
	REVISION			

© Copyright 2003 Martin Engineering. All rights reserved. Covered by U.S. and foreign patents pending and issued. ® and TM indicate trademarks of Martin Engineering.

MARTIN ENGINEERING

NEPONSET ILLINOIS USA

TITLE: MARTIN®QC™#1 HD ASM WITH TWIST DUAL™TENSIONER ASM 9 X 12 STEEL DOOR

SALES DRAWING

S37250-D

DRAWN MJT DATE 04/22/02
CHECKED
ENG. XJB
DATE 04/22/02
APPROVED JRB
DATE 04/22/02
SCALE 1/4=1