

Martin® QB1™ Cleaner HD



The **Martin® QB1™ Cleaner HD** introduces the next generation of belt cleaning technology.

A truly revolutionary innovation in belt cleaning design, the QB1™ Cleaner HD provides the cleanest belt and longest blade life—at the lowest cost.

FEATURES & BENEFITS

- Same ease of installation as current Martin® QC1™ Cleaners, maintaining standard installation and service costs.
- Utilizes Martin's highly effective, patented CARP profile, ensuring the highest level of cleaning performance expected from a Martin® Belt Cleaner.
- Utilizes Martin's innovative EVO® design principles to reduce component surface exposure to material flow, minimizing material build-up and the resulting clean-up costs, production interruptions and safety concerns.

SPECIFICATIONS

Maximum Belt Speed fpm (m/sec)	Maximum Service Temperature	Pulley Diameter** in. (mm)	Mounting Location in. (mm)	Wear Life* in. (mm)	Wear Volume (per inch of blade) in ³ (cm ³)
900 (4.6)	160°F (70°C) Continuous 180°F (82°C) Intermittent	16–22 (406–559)	3.5 (89)	4.5 (114)	6.53 (107)

* Amount of usable blade

** Pulley diameter 23 in. (584 mm) and greater: contact your Martin Engineering representative.

High-performance urethanes are available; see your Martin Engineering representative for assistance in specifying non-standard products. Refer to Form No. L3375.

NOMENCLATURE

39346 - XX 1X XX XX X

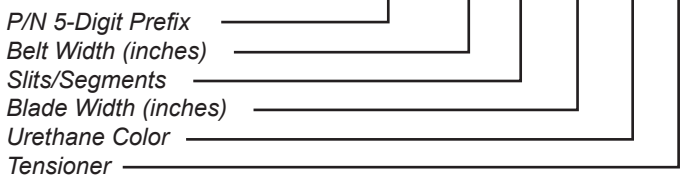

SLITS/SEGMENTS

- 11: No slits or segments
- 10: Segments only

TENSIONER

- T: Martin® Twist Tensioner
- S: Martin® Spring Tensioner

URETHANE COLOR

- BR: Brown
- NB: Navy Blue
- GR: Green
- CL: Tan
- OR: Orange

Use segmented blade on crowned head pulley.

MOUNTING LOCATION

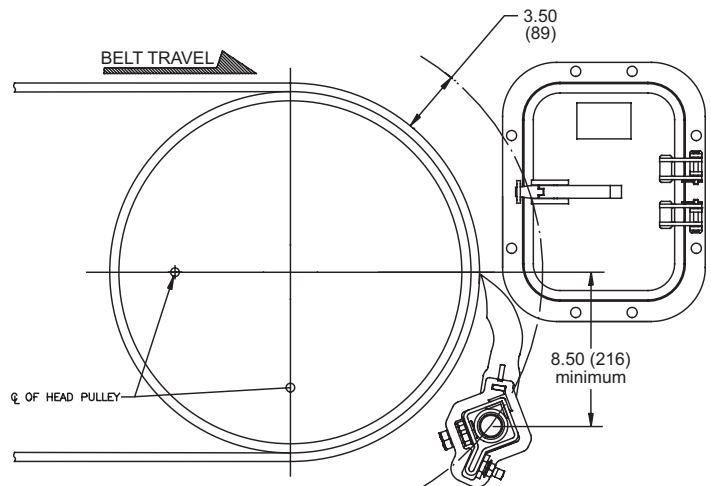

TECHNICAL DATA SHEET

DIMENSIONS -- in. (mm)

* Tensioner not included

Belt Width in. (mm)	Mainframe Length (B) in. (mm)	Belt Coverage (A) Belt Width Less 6" in. (mm)	Shipping Weight* lb. (kg)	Belt Coverage (A) Belt Width Less 2" in. (mm)	Shipping Weight* lb. (kg)
18 (400-500)	44 (1118)	12 (305)	40 (18)	16 (406)	43 (20)
24 (500-650)	50 (1270)	18 (457)	51 (23)	22 (559)	53 (24)
30 (650-800)	62 (1575)	24 (610)	63 (29)	28 (711)	66 (30)
36 (800-1000)	68 (1727)	30 (762)	71 (32)	34 (864)	73 (33)
42 (1000-1200)	74 (1880)	36 (914)	78 (35)	40 (1016)	81 (37)
48 (1200-1400)	80 (2032)	42 (1067)	86 (39)	46 (1168)	89 (40)
54 (1400-1600)	86 (2184)	48 (1219)	94 (43)	52 (1321)	96 (44)
60 (1600-1700)	98 (2489)	54 (1372)	106 (48)	58 (1473)	109 (49)
66 (1700-1800)	104 (2642)	60 (1524)	114 (52)	64 (1626)	116 (53)
72 (1800-2000)	110 (2794)	66 (1676)	121 (55)	70 (1778)	124 (56)
84 (2000-2200)	123 (3124)	78 (1981)	114 (52)	82 (2083)	116 (53)
96 (2200-2400)	135 (3429)	90 (2286)	135 (61)	94 (2388)	137 (62)

Note: Dual Tensioners are required for belt widths 54 in. (1400 mm) and greater.

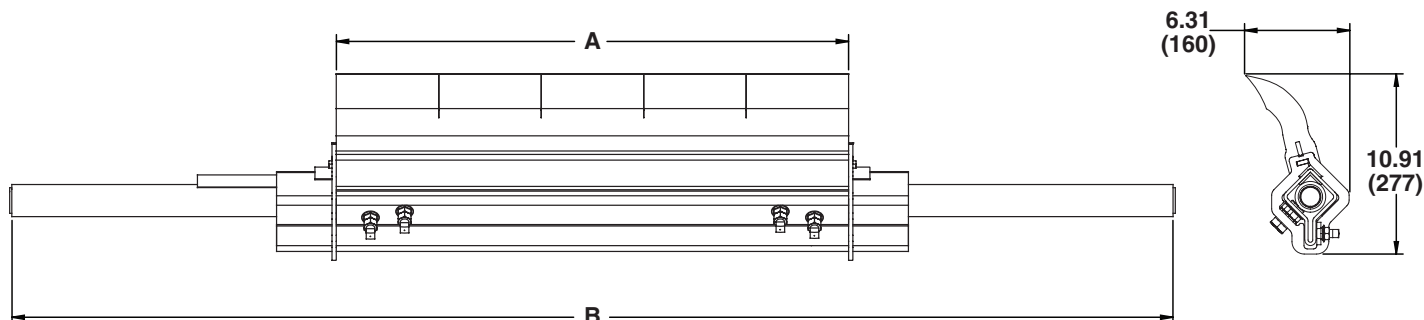

RECOMMENDED TENSIONERS & REPLACEMENT BLADES

Tensioner	P/N
Martin® Twist Tensioner	38850
Martin® Spring Tensioner	38180

Replacement Blade P/N
39344-XX1XXXXXX

ACCESSORIES

Part	P/N
Martin® Steel Inspection Door	CYA-1218
Martin® Hanger Mount Standard Assembly	27382

FREQUENTLY ASKED QUESTIONS

My Pre-Cleaner keeps flipping through.

The mounting location may be too far away from the belt. Relocate to the proper dimension. Replace the mainframe or end weldments if they are bent.

My Pre-Cleaner is wearing more in the center of the blade.

The blade is too wide for this application. Replace with a shorter length blade.



Martin Engineering USA

One Martin Place
Neponset, IL 61345-9766 USA
800 544 2947 or 309 852 2384
Fax 800 814 1553
www.martin-eng.com

**COMPANY WITH
QUALITY SYSTEM
CERTIFIED BY DNV
= ISO 9001:2008 =**

Problem Solved™ GUARANTEED!

Form No. L4021-04/17

© Martin Engineering Company 2015, 2017